

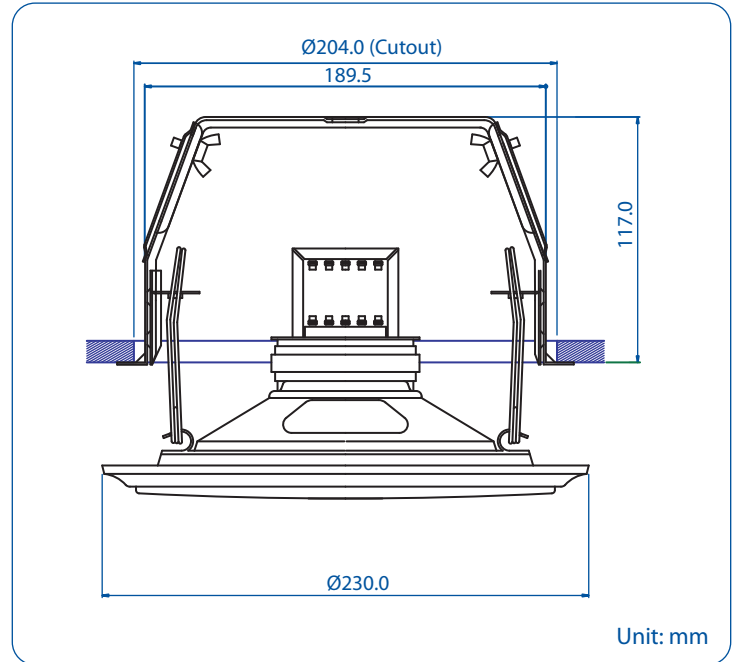

# QCM-6081T

## Quick-Mount 2-Way Ceiling Loudspeaker



- 100 Hours Life Tested
- CE Certified (EMC & LVD)
- IP Rated
- Rustproof
- UL94V0
- BS 5839 Part 8
- EASE Data
- RoHS Compliance
- UV Protected
- Withstanding/Insulation Tested

- Shares generic low profile grille design & simple fit system throughout entire QCM series.
- Featuring a high quality 6.5" 2-way speaker, with a paper cone, 10-ounce magnet and 2" tweeter with a bi-polar crossover.
- Foreground and sound reinforcement quality.
- 8 watt transformer with multi tapings down to 1W (100V) & 0.5W (70V).
- Built-in ceiling tile cutout marker.
- Dished grille design for acoustic integrity.
- Galvanized steel construction, finished in brilliant white (RAL 9003).

Model No.	QCM-6081T
Rated Power (rms)	8W
Impedance	1.25kΩ, 2.50kΩ, 5kΩ & 10kΩ
Power Taps @ 100V	8W, 4W, 2W & 1W
Power Taps @ 70V	4W, 2W, 1W & 0.5W
SPL (1W / 1M)	95dB
Max. SPL (Rated W / 1M)	104dB
Frequency Range (-10dB)	80Hz ~ 20KHz
Dispersion 1K Hz / 4K Hz	140° / 65°
Ambient Temperature	-20°C ~ +60°C
Power Selection	Plug
Material	Baffle: Steel, Grille: Steel
Colour / Finish	White (RAL 9003)
Dimensions	230.0 (9.06) Dia. X 121.0 (4.76) Height mm. (in.)
Cutout Size	204.0 (8.03) Dia. mm. (in.)
Net Weight (ea)	1.70 kgs (3.75 lbs)
Mounting	Spring loaded Quick-Mount Bracket Assembly