

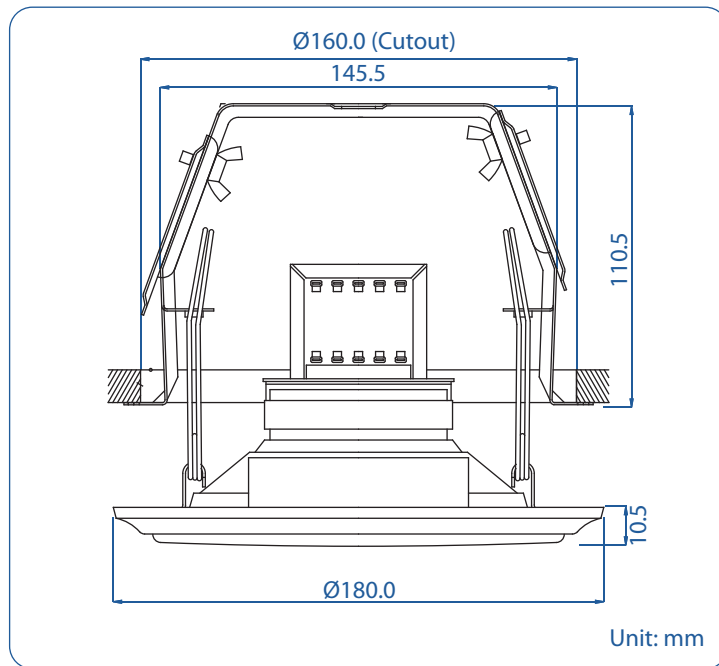

# QCM-5061

## Quick-Mount Ceiling Loudspeaker

Public Address



- 100 Hours Life Tested
- CE Certified (EMC & LVD)
- IP Rated
- Rustproof
- UL94V0
- BS 5839 Part 8
- EASE Data
- RoHS Compliance
- UV Stable
- Withstanding/Insulation Tested

- Fitted with a 5.25" twin cone driver unit
- Designed to offer wide response for music & speech
- Dished grille design for acoustic integrity
- Finished in white

| Model No.                | QCM-5061   |
|--------------------------|--|
| Rated Power (rms)        | 6W   |
| Impedance                | 1.67kΩ, 3.33kΩ, 6.67kΩ & 13.33kΩ                 |
| Power Taps @ 100V        | 6W, 3W, 1.5W & 0.75W                             |
| Power Taps @ 70V         | 3W, 1.5W, 0.75W & 0.375W                         |
| SPL (1W / 1m)            | 92dB   |
| Max. SPL (Rated W / 1m)  | 99dB   |
| Frequency Range (-10dB)  | 100 Hz ~ 20k Hz                                  |
| Dispersion 1k Hz / 4k Hz | 140° / 70°                                       |
| Operating Temperature    | -30°C ~ +60°C                                    |
| Power Selection          | Plug   |
| Material                 | Baffle: Steel, Grille: Steel                     |
| Colour / Finish          | White  |
| Dimensions               | 180.0 (7.09) Dia. X 121.0(4.76) Height mm. (in.) |
| Cutout Size              | 160.0 (6.30) Dia. mm. (in.)                      |
| Net Weight (ea)          | 1.30 kg (2.87 lb.)                               |
| Mounting                 | Spring loaded Quick-Mount bracket assembly       |

■ **Rated Power according to IEC 60268- 5 100 hours Power Handling Capacity standard**